A Single YAGI 'Total Flux' Radiometer for 81MHz

A Single YAGI 'Total Flux' Radiometer for 81 MHz

Mr. C. W. Clements

Basic Considerations

What follows is a description of a basic single YAGI *Total Flux* Radiometer intended primarily for the beginner. The aerial is a YAGI designed for the official (in the United Kingdom) Radio Astronomy frequency allocation at 80.5 to 82.5 MHz (a wavelength of approximately 3.7 metres), and provides reasonable gain for this frequency with significant directivity. This particular frequency allocation is unique to the UK and retained 'for historical reasons'. Elsewhere in the world the equivalent allocation is around 73 MHz. The receiver is an Eddystone 990R produced from the late 1960s' to the early 70s' and examples can often be found on eBay. This VHF receiver has several features that make it particularly suitable for the present project:-

- 1). Its AGC (Automatic Gain Control) can be switched off from the front panel),
- 2). It has two IF bandwidth settings, 30 KHz and 200 KHz, the latter being especially suitable for this project.
- 3). The receiver has a 10.7 MHz IF output, originally intended for driving a 'Panadaptor', but allowing the use of further external IF amplification.
- 4). It's wide frequency coverage (25 MHz to 250 MHz) facilitates access to the two other VHF Radio Astronomy allocations at 38 MHz and 151 MHz

An alternative receiver (of current manufacture) is the AOR AR5000; this unit encompasses all the key features of the Eddystone 990R together with a vastly expanded frequency coverage, but it's 4-figure price tag will make it prohibitively expensive for many. However, second-hand examples may occasionally be found on eBay.

Originally, additional RF pre-amplification was used in the form of a tuned MosFET unit followed by a wide-band pre-amplifier employing low noise transistors, but the gain this resulted in was found to be excessive. Both pre-amplifiers were removed and the Radiometer was found to operate successfully without them.

A Single YAGI 'Total Flux' Radiometer for 81MHz

System Layout

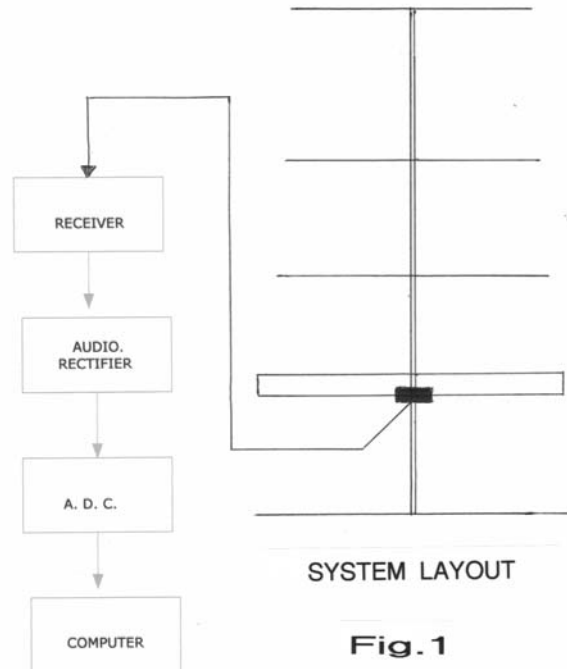

The diagram in Fig.1 illustrates the system layout; the aerial is a 5-element YAGI (Figs' 2, 3, and 4) with a calculated gain of 8.3dB and an estimated horizontal beam width of around 50 degrees.



A Single YAGI 'Total Flux' Radiometer for 81MHz

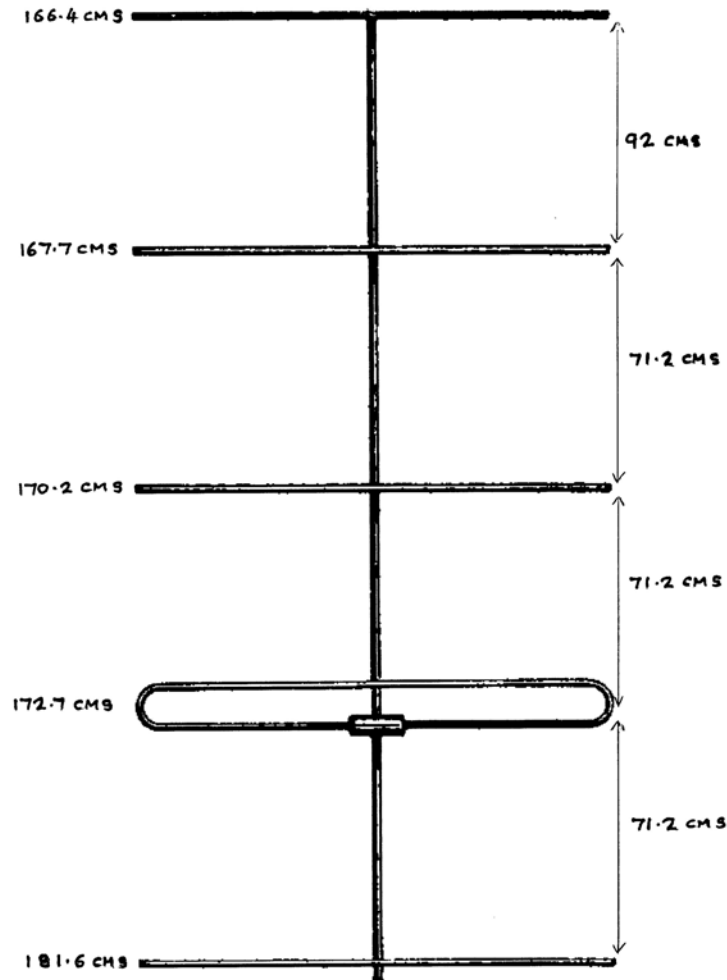
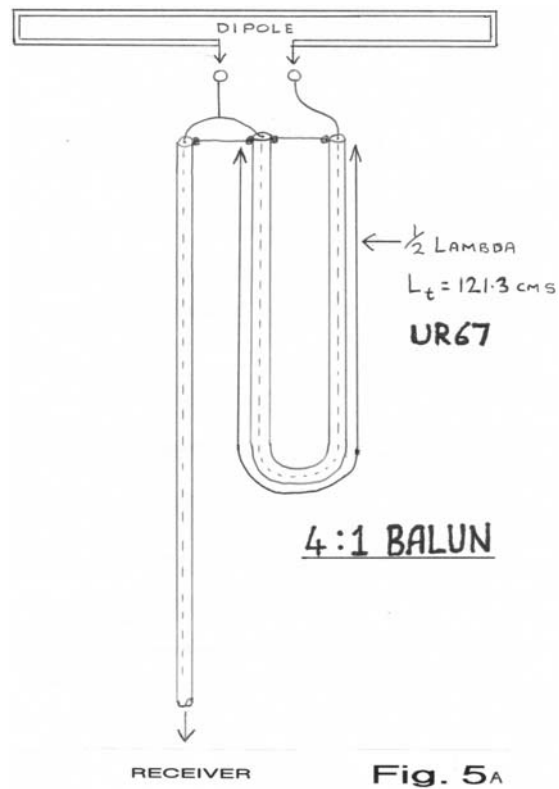
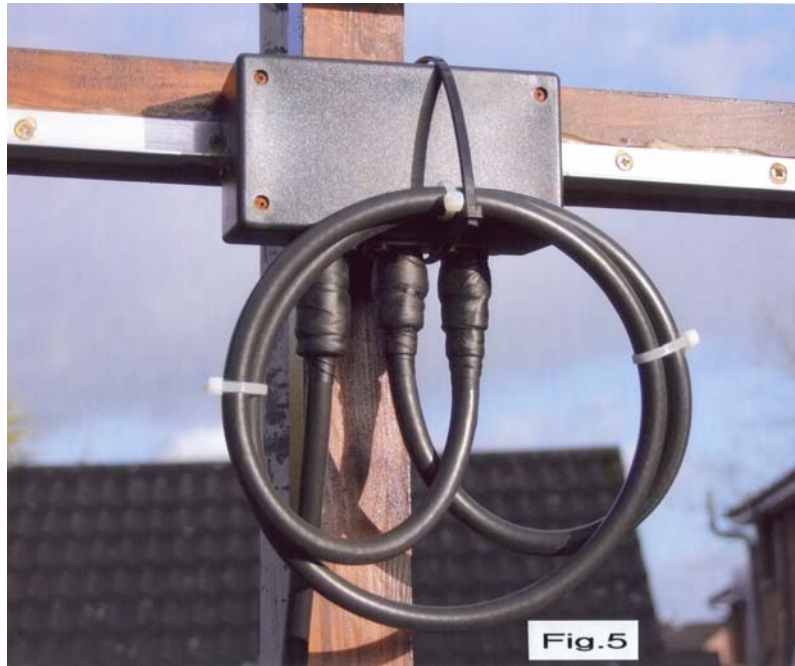

Fig.4

As a 'Folded Dipole' is employed (with a characteristic impedance of 300 ohms), a 4:1 coaxial balun (Figs. 5 and 5A) is employed to reduce this high impedance to a level consistent with that of the feed cable. The reflector, driven element, and directors are $\frac{3}{4}$ " angle aluminium. The aerial is fed directly to the receiver using UR67 RF cable; the audio output from the 990R is then fed into a rectifier / integrator / DC amplifier of basic design (Fig. 6). Integration is continually variable up to 47 seconds, with a maximum DC gain of 25. *No originality whatever is claimed for this circuit*, nor should it be considered in any way 'definitive'. Further development is possible, and other technical approaches may be employed.

A Single YAGI 'Total Flux' Radiometer for 81MHz



A Single YAGI 'Total Flux' Radiometer for 81MHz

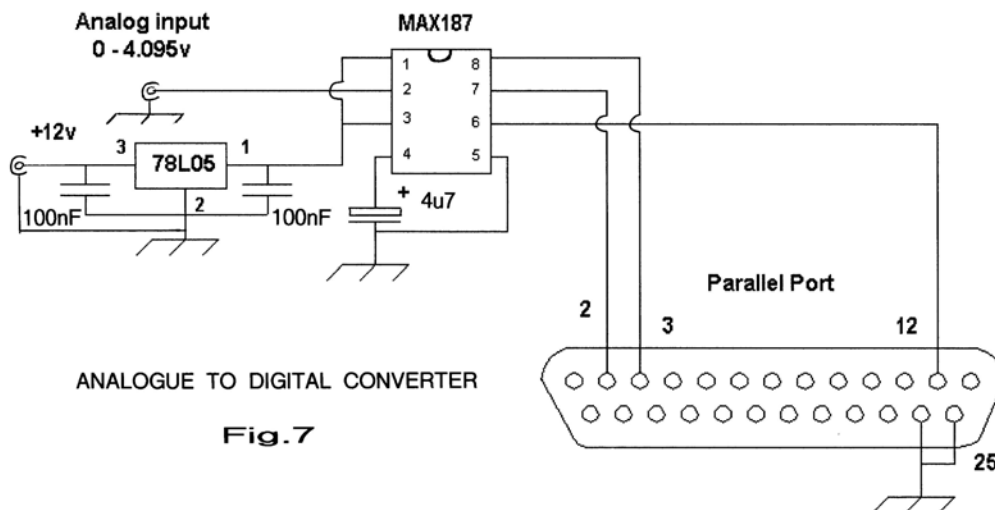
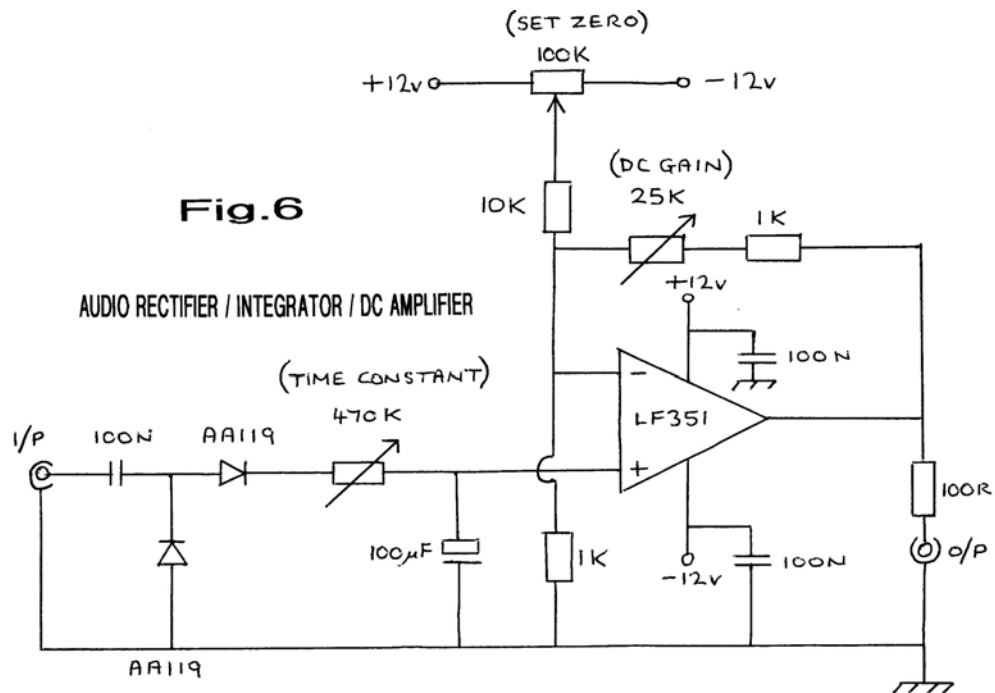

The output from this unit is fed into a single-channel 'Analogue to Digital Converter' employing a MAX187 integrated circuit (Fig. 7), and then to a computer running the 'Radio SkyPipe' data-logging programme.

'Drive' to the audio rectifier unit is taken from the headphone socket on the receiver front panel, and the volume control acts as a convenient 'gain' control.

A Single YAGI 'Total Flux' Radiometer for 81MHz

For operational testing the aerial was orientated vertically upwards towards the local zenith (54 degrees 31 minutes north) and vertically polarised. This would allow the Radiometer to 'see' the Plane of the Galaxy, the radio sources' *Cassiopeia A*, and possibly *Cygnus A*.

Observational Data

Fig. 8 is a chart showing a drift scan obtained on 2011-1-17. What is believed to be the outer edge of the Galactic Plane can be seen to transit the aerial beam in the early morning with the *Cassiopeia 'A'* radio source registering prominently in the early evening. The charts in Figs' 9 and 10 provide confirmation and were obtained on the 18th of January and the 1st of March 2011 respectively. The remaining charts are expanded examples showing one transit of a Galactic arm with the radio source *Cassiopeia 'A'*. Figs' 11, 12, and 13 show the *Cass 'A'* transit in more detail for the three previous dates. No attempt has been made to identify other radio sources that may be present on these charts, but a general sky survey is eventually planned for this Radiometer, as part of a programme of on-going tests.

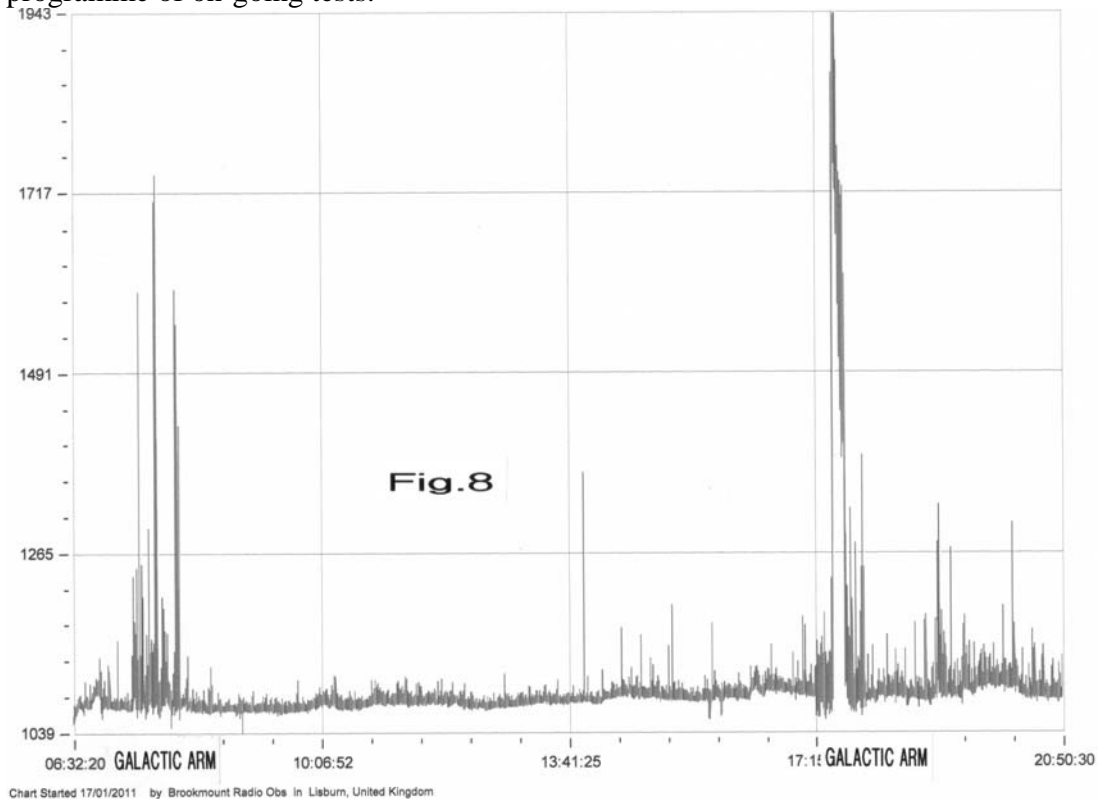

A Single YAGI 'Total Flux' Radiometer for 81MHz

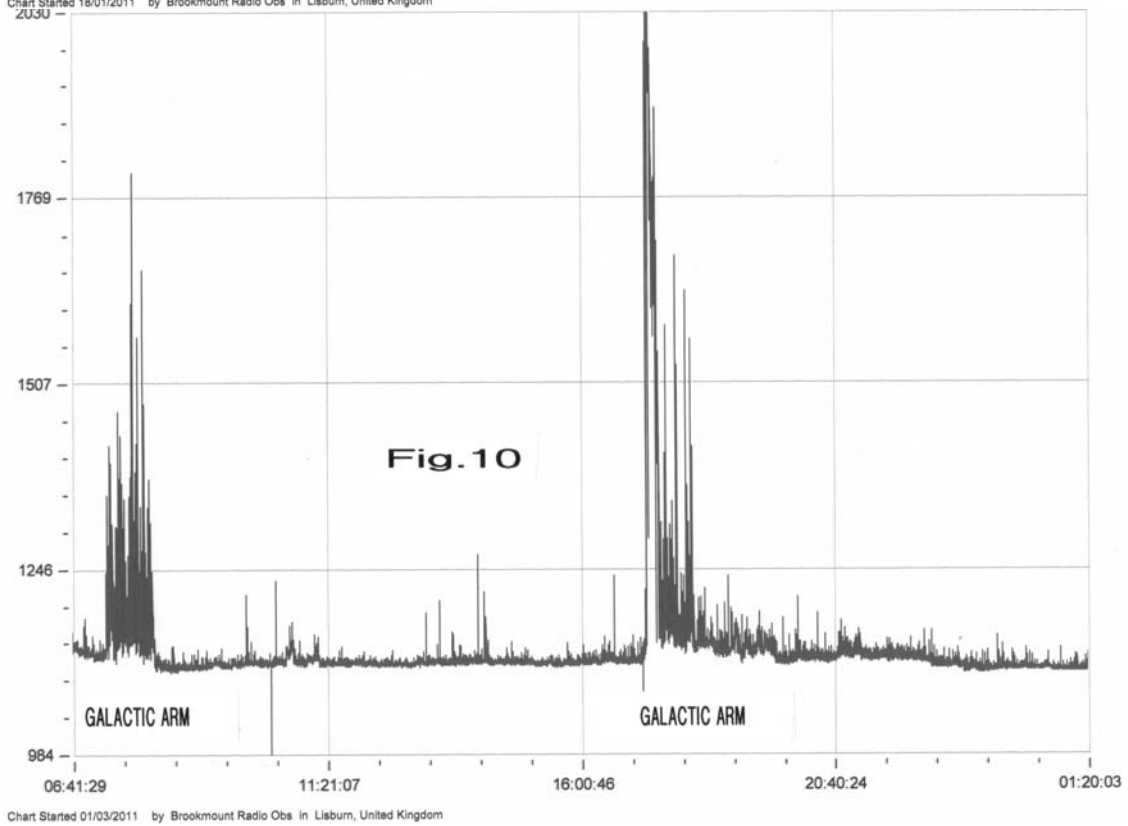
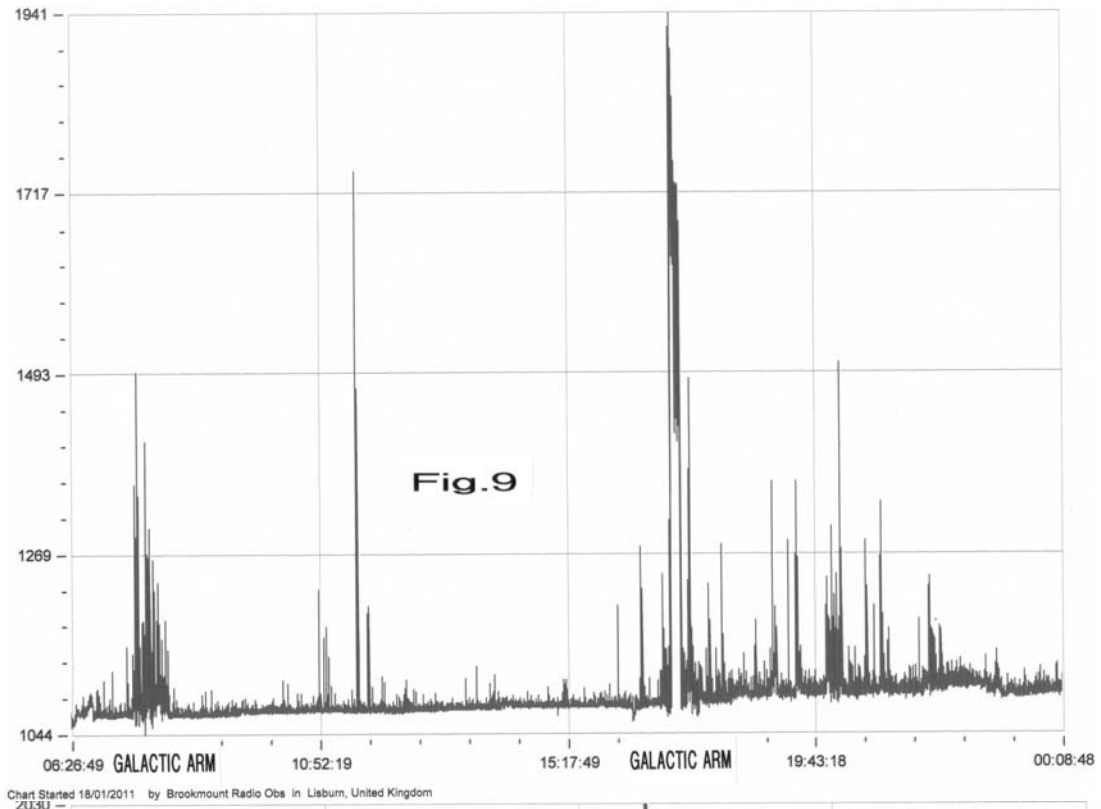

A Single YAGI 'Total Flux' Radiometer for 81MHz

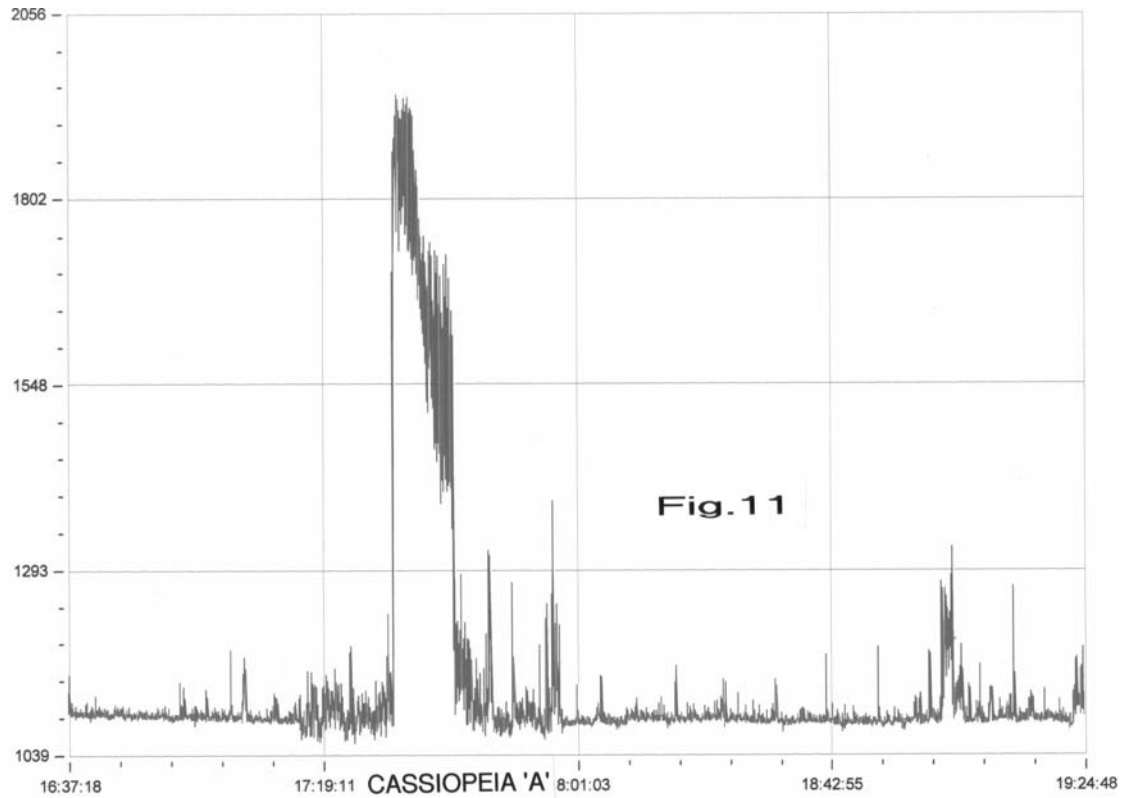

Chart Started 17/01/2011 by Brookmount Radio Obs in Lisburn, United Kingdom

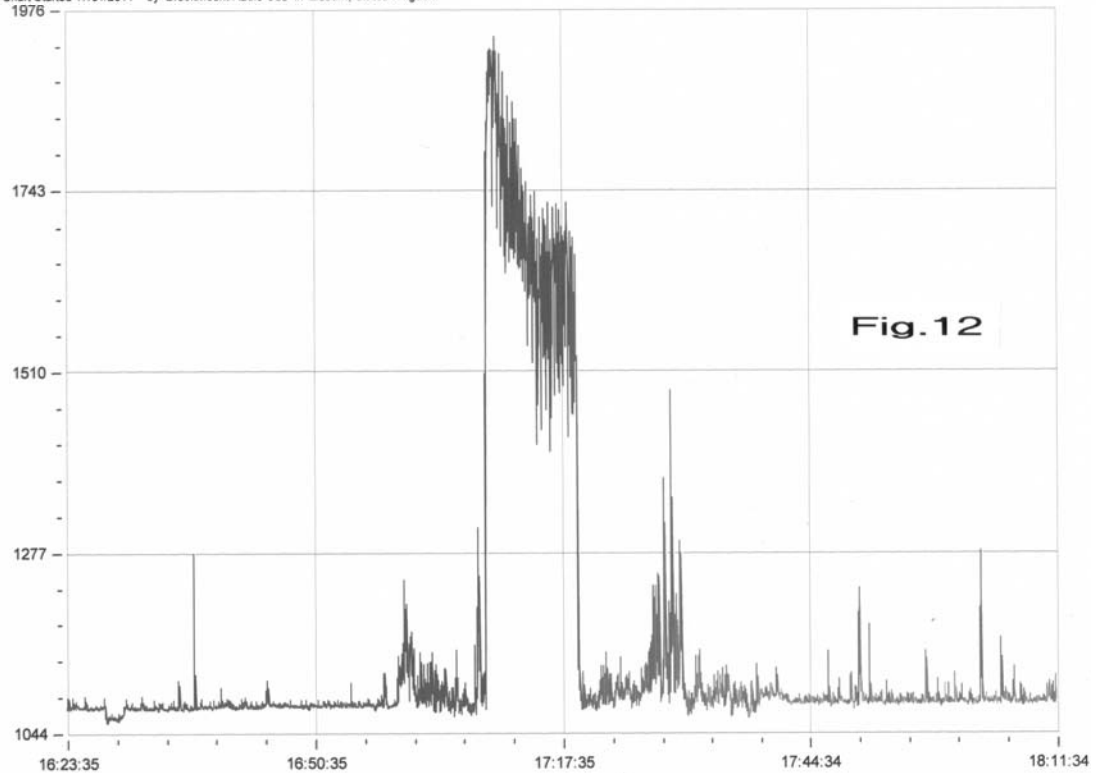

Chart Started 18/01/2011 by Brookmount Radio Obs in Lisburn, United Kingdom

CASSIOPEIA 'A'

A Single YAGI 'Total Flux' Radiometer for 81MHz

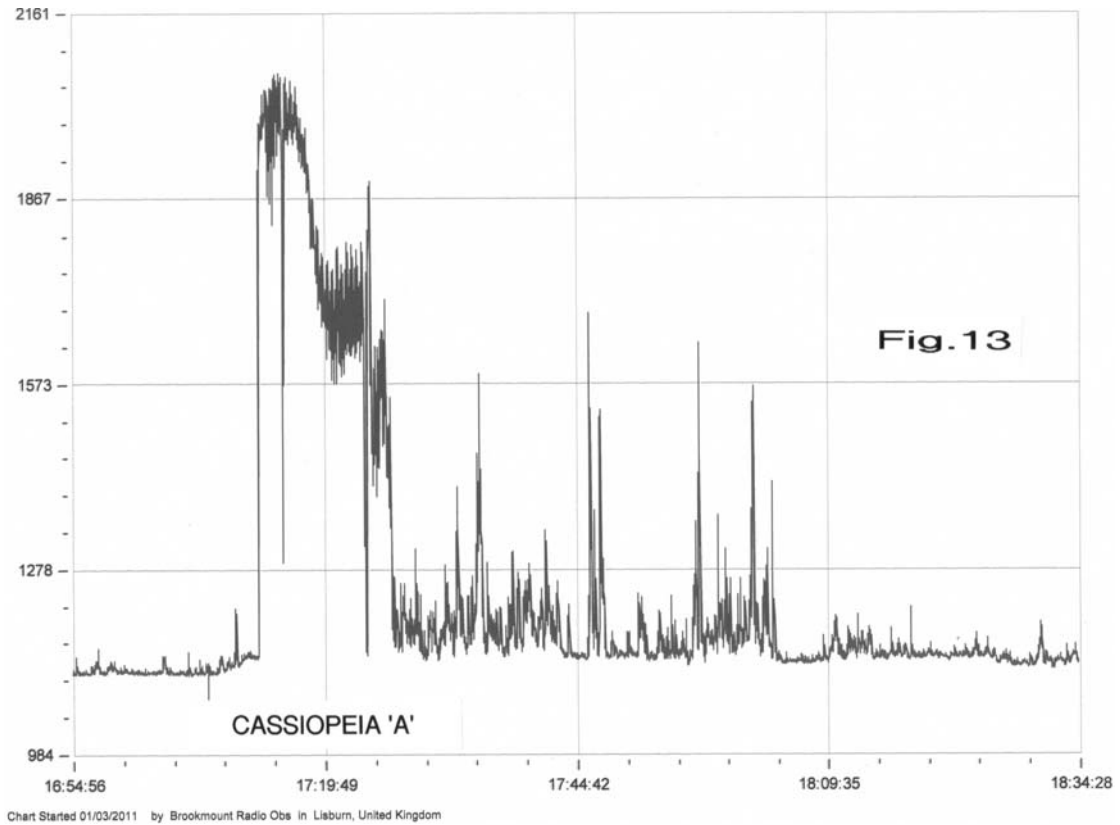

Fig 14 Eddystone 990R Receiver

A Single YAGI 'Total Flux' Radiometer for 81MHz

System Settings

For the preceding observations, the receiver front-panel controls were set as follows:-

Receive mode	AM
Volume	75%
A.G.C	Manual
Selectivity	Wide
I.F. gain	100%
R.F. gain	50%
Muting	Off
Cal	Off
L.S	Off

Integration was set at 40 seconds with a DC gain of 10, the capabilities of the '**Radio SkyPipe**' programme being used to enhance various aspects of individual charts, e.g. amplitude.